

# Tribrid<sup>®</sup> Tag B1 S

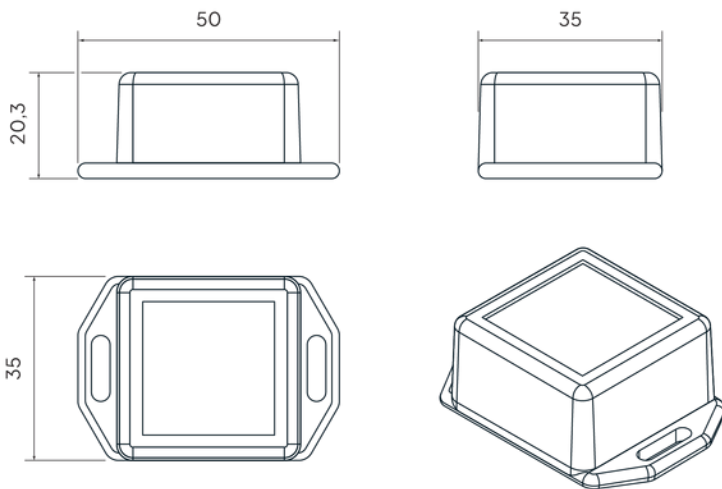

AoA

In- /Outdoor | Article nr: 03.01.08



## Battery Life

Up to 10 years\*

# Tribrid<sup>®</sup> Tag B1 S

The Tag integrates Cavea<sup>®</sup> Wirepas Mesh, Bluetooth Low Energy (BLE), and Angle of Arrival (AoA) into a single device. This allows for flexible adaptation to various use cases, enabling the user to select the appropriate technology based on the specific application.

## Mounting

The tag can be attached as needed using adhesive, cable ties, or Velcro tape. This allows the TRIBRID<sup>®</sup> Tag to be easily mounted on various objects, ensuring reliable tracking.

## Battery Life

The stated battery lifetimes are based on operation with BLE technology. When using AoA or Cavea Wirepas Mesh at a faster update rate, this results in a shorter battery life.



L: 50,00 mm  
W: 35,00 mm  
H: 20,30 mm



CR2477  
1.000 mAh



-10 till 60° C



26 g



IP68

\*Depending on configuration

## Features



From < 1 m to 7 m accuracy depending on technology



Secure data transfer



Exchangeable battery



Made in Europe



Easy installation



omlox compatible



3-Axis-G sensor



Cavea<sup>®</sup> software

## Compatible With The Following Hardware



**Tribird  
Anchor A1**



**Tribird  
Locator L1**

---

## Additional Benefits

### Scalable

Track thousands of objects simultaneously and expand your system at any time – completely flexible.

### Cost-Efficient

The combination of tracking technologies ensures maximum efficiency and a compelling ROI.

### ISO-Compliant

The tag complies with the ISO/IEC 15693 (NFC Forum Tag Type 5) and ISO/IEC 14443 (NFC Forum Tag Type 2) standards.

